



Electrical Engineering Department  
California Polytechnic State University

---

## Senior Project Report

---

# HVAC Fan Control Using Modicon M580

June 10<sup>th</sup>, 2020

Kevin Shipp  
Anthony Tyler

Professor Taufik

**TABLE OF CONTENTS**

<b><u>Section</u></b>		<b><u>Page</u></b>
I.	Acknowledgements	3
II.	Abstract	4
III.	Chapter 1: Introduction	5
IV.	Chapter 2: Background	9
V.	Chapter 3: Design Requirements	12
VI.	Chapter 4: Design	16
VII.	Chapter 5: Simulation	21
VIII.	Chapter 6: Conclusion	31
IX.	Appendix A: Scheduling	33
X.	Appendix B: Bill of Materials	34
XI.	Appendix C: ABET Senior Project Analysis	35
XII.	References	39

## LIST OF TABLES AND FIGURE

<u><b>Table</b></u>	<u><b>Page</b></u>
3-1 Number of Fans ON	14
3-2 Summary of Design Requirements	14
4-1 Cooling Side Pins	17
4-2 Bill of Materials and Purchase Links	19
4-3 Component Datasheets	20
5-1 Simulation test without faults	27
5-2 Simulation Testing Faults	29
B-1 Bill of Materials for Current Project	34
B-2 Bill of Materials for Previous Project	34
C-1 Economic Impacts	35
C-2 Commercial Manufacturing	36
<u><b>Figure</b></u>	<u><b>Page</b></u>
1-1 Schneider Electric's first ePAC, the Modicon M580	6
1-2 A brief overview of the 5 different languages used for PLCs	7
1-3 HVAC model with PLC I/O	8
3-1 Level 0 Block Diagram	12
3-2 Level 1 Block Diagram	13
4-1 Heating Side Design	16
4-2 Cooling Side Design	17
4-3 Cooling Side Fan	18
5-1 Simulation set up- step 3: New Simulation files	22
5-2 Simulation setup step 5: Inserting new blocks	23
5-3 Simulation setup step 6: Block type selection	24
5-4 Simulation setup step 11: Inserting variables and changing values	25
5-5 HVAC System Function Block Diagram for Simulation	26
5-6 No fault simulation of increasing to temperature of 50°C	28
5-7 No fault simulation of decreasing to temperature of 90°C	28
5-8 Simulation Increasing to temperature 80°C with fault 1 triggered	30
5-9 Simulation Decreasing to temperature 90°C with fault 1 and 2 triggered	30
A-1 Fall Quarter 2019 Gantt Chart	33
A-2 Winter Quarter 2020 Gantt Chart	33
A-3 Spring Quarter 2020 Gantt Chart	33

## **Acknowledgements**

There are many people we would like to thank for their encouragement in our graduation and completion of this project. Most importantly, our Advisor, Professor Taufik, who guided us throughout the entire process and Schneider Electric, for donating the PLCs and providing educational workshops. We could not have completed this without the two of them. We want to thank our families for their continued support in our college careers. Thank you to Nadir Khan, Michael Campos, Samantha Bituen, and the rest of the graduated seniors who started this PLC project. Their initial work in this multipart lab creation provided crucial references for our own project. Lastly, we would like to thank Eileen Tran and Brittany Won, our sister team in this PLC lab project, for learning and working with us.

## **Abstract**

This project is the start of a lab experiment for the Cal Poly San Luis Obispo Electrical Engineering department's new lab focusing on Programmable Logic Controller's (PLCs). The primary focus is to create a lab where students control a Heating, Ventilation, and Air conditioning (HVAC) system controlled by the Modicon M580 PLC, donated by Schneider Electric. The experiment contains a heat source, which the PLC monitors with a temperature sensor, and a cooling source with multiple fans. Students will learn to use function block diagrams to program the PLC, controlling fan output and regulating the system temperature. The experiment specifications and HVAC system parameters were created and simulated with the Modicon M580's software program, Unity Pro XLS. This simulation confirmed a working design that students would be able to recreate themselves in a lab setting and program to work. Students can gain a working knowledge of a commonplace industrial control/automation tool.

## Chapter 1: Introduction

The first programmable logic controller, or PLC, was developed in 1968 by Dick Morley and the company Modicon [1]. Modicon stands for modular digital controller, which is what the PLC sought to provide for companies worldwide. Current applications for PLCs today include industrial control, automation for production, and a multitude of other manufacturing processes. The PLC has largely replaced traditional electromechanical relay systems, which were larger, messier, and prone to failure. From the inception of PLCs, with the Modicon 084, to the current Modicon M580 ePAC, engineers have found more ways to automate control loops, monitor the environment, and provide real-time feedback on operating conditions. This has led to an increase in the complexity of PLCs, but also allows them to be used more robustly.

One year after Morley's Modicon 084, Schneider Electric began working on the new PLC product [2]. The first major change Schneider produced was in 1996, when the Modicon Premium was released. This was a high-capacity controller for large applications and pioneered the way for Programmable Automation Controllers (PACs) [2]. As the internet age began to boom, the Modicon Quantum PAC was released in the early 2000s. This PAC offered embedded web server capabilities and made communication easier and more reliable. Leading up to the Modicon M580, more adjustments were made to PLCs, adding functions such as Ethernet, Modbus ports on CPUs, and native USB ports. Schneider's Modicon M580, was the first ePAC, a PLC with a standard unmodified ethernet built into the core. This PLC started the current generation of PLCs, boasting high processing power and memory, along with reduced energy consumption and improved productivity.



Figure 1-1: Schneider Electric's first ePAC, the Modicon M580 [3]

The actual process of automation that a PLC performs has 3 main categories: Processing, Input, and Output [3]. Similar to a CPU, a PLC monitors the inputs and the status of switches, sensors, etc. With the information from them, PLC performs logic on the inputs during the processing section, and proceeds to output the logic to motors, valves or other outputs. In addition to the 3 activities the PLC also has a housekeeping process where a system scan ensures that there are no anomalies. The programming for the PLCs processing activities follows the International Electrotechnical Commission's five standard languages. These include, ladder diagrams, functional block diagrams, sequential function chart instructional list and structured text.

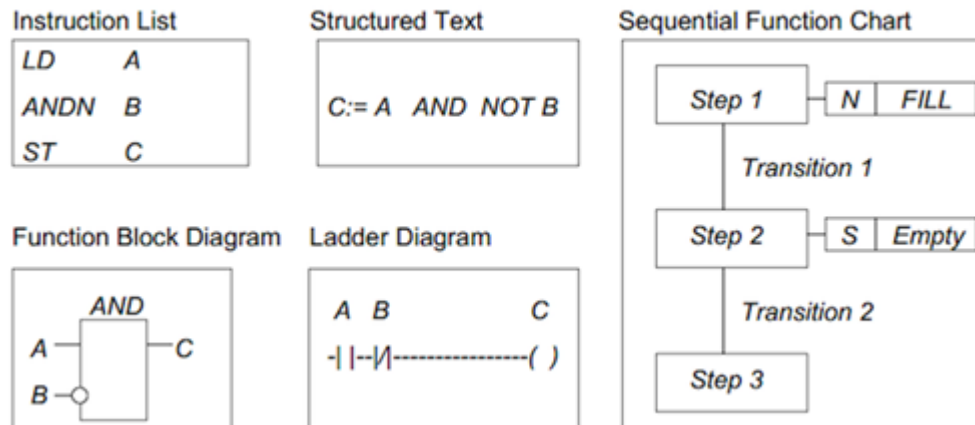

Figure 1-2: A brief overview of the 5 different languages used for PLCs [4]

Common PLC I/O can be handled for both discrete and analog values. Signal values such as 4-20mA, 0-20mA, 0-10V, 1-5V and a multitude of other ranges can be accepted and used to drive PLC outputs for any desired function. I/O modules, or individual blocks with specific functions, are used depending on the existing sensors and required inputs. This mutable architecture allows for, to be added or removed based on the needs of the facility, ultimately enhancing the usefulness of PLCs for automation control and process flow.

One of the more prevalent use of PLCs is in the HVAC (heating, ventilation, and air conditioning) system. HVAC is a crucial component of construction that ensures stable temperature indoors, while recirculating and filtering air throughout the structure. With today's technology, HVAC-specific PLC systems have been developed, allowing a single operator to control ventilation and heating for large structures via ethernet, RS-232, or other supported communication protocol [5].



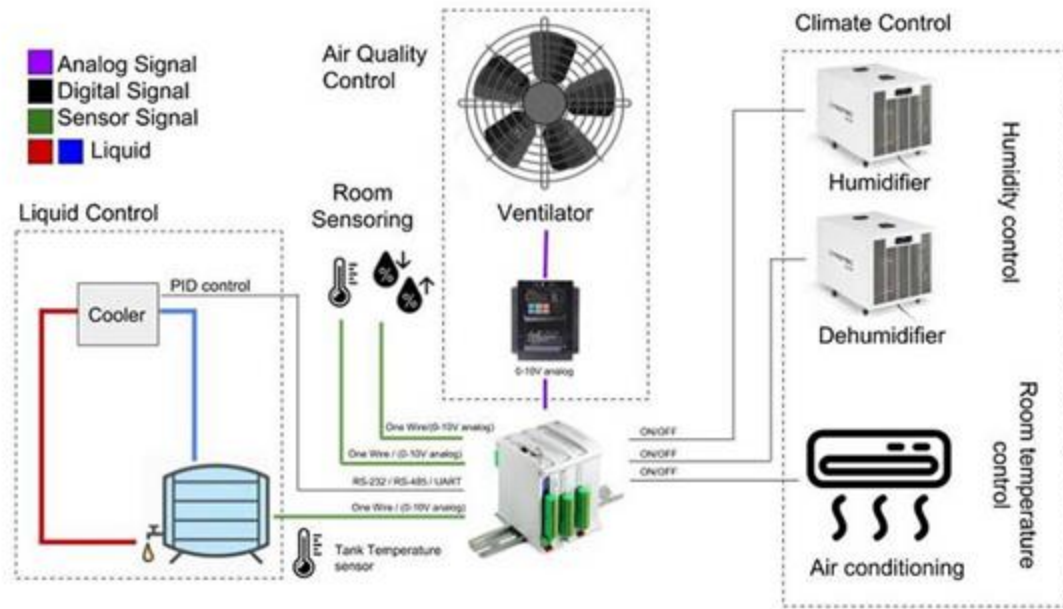

Figure 1-3: HVAC model with PLC I/O [6].

## Chapter 2: Background

The power industry continues to expand as industrial power controls and automation make advancements. Power equipment found in HVAC systems, relays, lighting systems, and any motorized system utilizes industrial power controls with the implementation of PLCs. With industrial usage of PLCs increasing rapidly over the past couple decades, entry level engineers should have a chance to learn and operate PLCs while in academia. Currently, the only PLC class at Cal Poly SLO is offered by the Industrial & Manufacturing Engineering department, and it primarily focuses on automation. This means there is no class that electrical engineers can take to expose them to PLCs and the programming needed to operate them. To address this issue, there is currently a plan to create a new lab course that can be offered to EE students and teach them about automation and the necessary programming. In addition to studying PLCs and their usage in industry, the lab will provide students with hands-on experience and exercises. Many other courses both at Cal Poly and on other college campuses may only provide theoretical coverage of the topic, and this new EE course hopes to break that norm.

Previous work has been done in developing this course since the 2018-2019 academic year, thanks to the help of a previous senior project [7]. They assisted in the creation of the industrial automation lab, complete with 6 PLC stations. In addition, they created the first lab for this course, and optimized the layout of the DIN rail, which holds circuit breakers, and industrial control equipment. The remaining work to be done includes developing the rest of the labs and writing the lab manual. Their idea for the course was to allow students to explore a potential career path, getting an overview of industrial automation while gaining hands-on experience with an industry standard PLC.

With the creation of this course underway, the issue of what topics to cover and experiments to perform in the lab arises. This project covers the creation of one of those labs, which specifically focuses on motor control and HVAC, teaching students the importance of automation inclusion for HVAC. It also covers additional PLC programming for the inclusion of temperature sensors. The motor control and HVAC lab being created is based on an existing design. The original design covers the programming aspect needed to control fans for a cooling system [8]. This project expands that design by including a temperature sensor and external heat source. This allows for more control of the overall system and a greater learning experience for students. By the end of the lab, students should be able to show their understanding of PLCs by writing program instructions to the PLC to control a contained HVAC system containing temperature stabilizing fans.

The need for PLCs in the HVAC field grows exponentially as industries use more heat exhausting machinery [9]. HVAC systems play an important role maintaining temperatures and humidity levels in a work area. With the inclusion of PLCs, changing levels of temperature can be monitored with sensors and adjusted accordingly. The HVAC system can rely on a PLC to monitor the input levels and tell it what output is needed to maintain the necessary temperature for the machinery to keep functioning. Entire buildings can be controlled from a single computer, and large systems can be daisy-chained in a ring-like topology, protecting against failure anywhere in the ring. Automated temperature control via PLC has enabled the production of highly modular HVAC systems, capable of handling the needs of current and future structures worldwide.

Student's interest in PLCs and automation grows as more courses are developed and students are exposed. The University of Wyoming has created their own lab and already

implemented it into their curriculum [10]. Their reports show student feedback, and interest in the growing field of PLCs. Despite the difficulties in learning a relatively new field of study, many of the students eagerly said they would take another class on PLCs if offered. More importantly, when asked about their PLC knowledge on a scale of 1-10, the average response before the class was 2.2 and after taking the course, was 6.1. This shows the importance of inclusion of a PLC course at any college. Many students have little to no knowledge, and although one class might raise it significantly, there is still a lot they could learn. Including a PLC course at Cal Poly SLO will help broaden students' knowledge and prepare them for potential employers. This is especially important when considering the direction of manufacturing, which emphasizes speed and efficiency without sacrificing control. PLCs are the future of automated manufacturing and control, so making a class to address this valuable industry is warranted.

Realizing the importance of gaining the necessary knowledge and skill in PLC for electrical engineering students, the objective of this project as stated before is to design and develop a laboratory exercise on motor control in HVAC application. In addition to the hardware setup for the experiment, a lab manual detailing instruction on how to conduct will also be included as the outcomes of the project.

### Chapter 3: Design Requirements

The industrial power and controls lab being developed at Cal Poly SLO has moved into the lab experiment production phase. One of these labs is to include an adjustable speed drive for motor control. The design of the lab should combine PLCs with motors and create an enjoyable and hands on experience for students taking the course. Ideally it will contain a variety of subject matter from mechanical and electrical disciplines, separating it from traditional electrical engineering labs and providing an interactive experience.

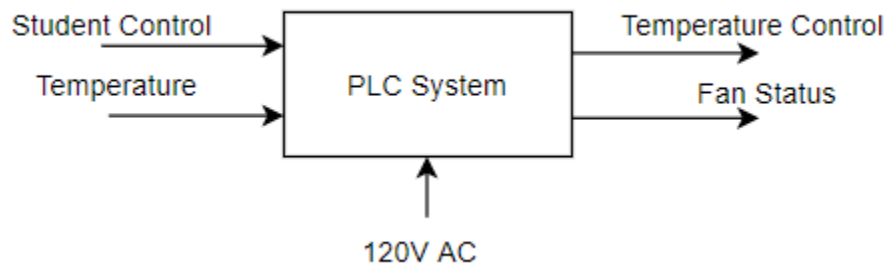

Figure 3-1: Level 0 Block Diagram

The lab experiment being designed is a miniaturized HVAC system model, controlled by PLC. Figure 3-1 shows the level 0 block diagram and Figure 3-2 shows the level 1 block diagram for this proposed HVAC system. The 120V AC input is power supplied to the PLC system from the room's outlets and is connected to the PLC and external power supply. The additional power supply, Agilent/HP E3640A, provides a voltage range of 0-20 V. This is sent to the resistive load, which is nichrome wire. It acts as a low-ohmage heat element, which can be controlled by the power supply. From the power supply there is a large range of temperatures that will be detected by the system. The negative temperature coefficient (NTC) thermistor is connected to

the Modicon M580 PLC via I/O pins provides the system with the temperature input status. The PLC takes this information and with the programming that students have written and sent to the PLC via ethernet, it will process the data and output accordingly.

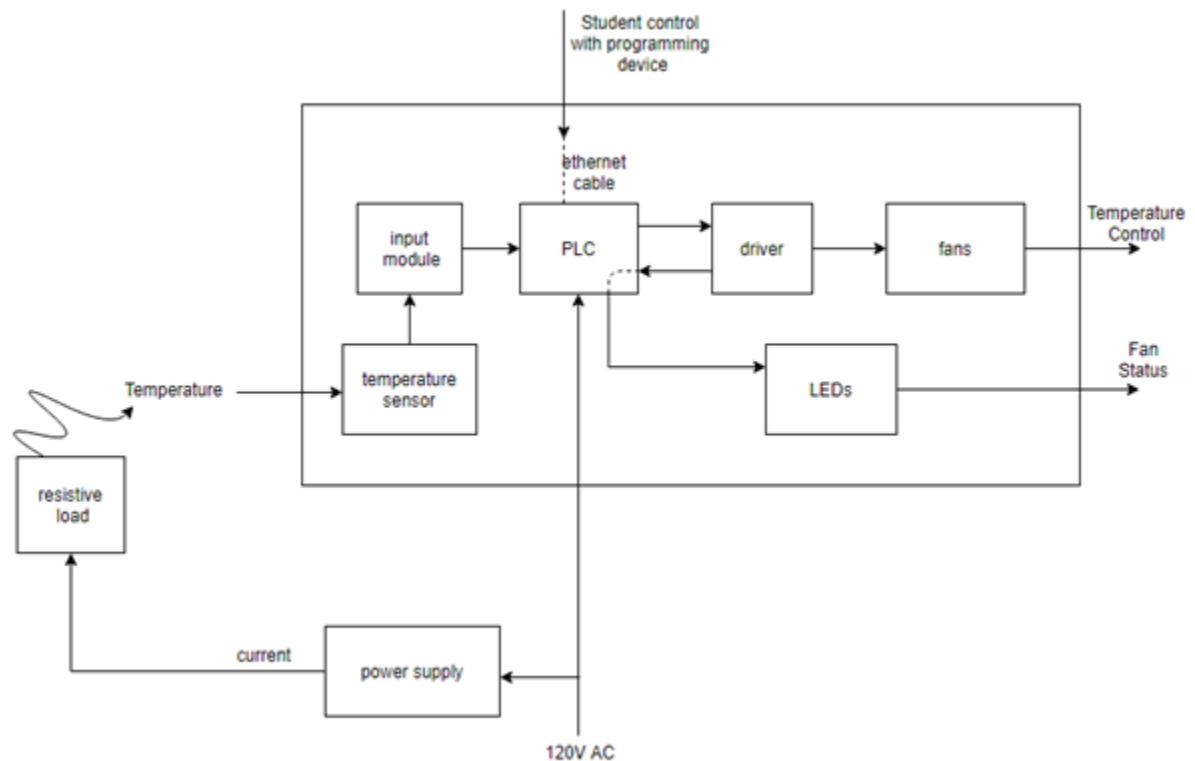

Figure 3-2: Level 1 Block Diagram

The output of the system is temperature control and regulation of the environment around the temperature sensor. The variability comes from the number of Panaflo FBA08T12L fans that are connected to the PLC with the AH5775 brushless DC (BLDC) drivers, which provide the required current to the fans. The DC computer fans operate based off the students programming, which should follow the requirements in Table 3-1. The temperature range that Table 3-1 is based off will depend on the student's surroundings and conditions, requiring them to calibrate it themselves.

Table 3-1: Number of Fans ON

Temperature	Number of fans
“Room Temperature” calibrated as 0°C	0 fans are on
“0.5X” °C	Transition from 1 to 0 fans
“X” °C	1 fan turns on
“1.5X” °C	Transition temperature from 2 to 1 fan
“2X” °C	2 fans are on

In addition to the number of fans being on, there are LEDs that output the status of the fan and whether each individual one is working. The PLC gets information from the drivers, monitoring the fans and relays that information to the students via LED signal.

Table 3-2 summarizes the engineering design specifications for the HVAC PLC proposed lab experiment.

Table 3-2: Summary of Design Requirements

Requirement	Engineering Requirement
Agilent/HP E3640A Power supply	<ul style="list-style-type: none"> <li>● Maximum power: 30 W</li> <li>● Voltage range: 0 - 8V or 0 - 20V</li> <li>● Current range: 1.5 - 3amps</li> </ul>
Nichrome Wire (heat production)	<ul style="list-style-type: none"> <li>● 100 ft of nichrome wire</li> <li>● Melting temperature 1400 °C</li> <li>● Resistance: 1.6089 ohms/ft</li> </ul>

NTC Thermistor (temperature sensing)	<ul style="list-style-type: none"> <li>● Resistance @ 25°C: 47kΩ</li> <li>● Thermal dissipation constant: 1.5mW/°C</li> <li>● Maximum power: 7.5mW</li> </ul>
Modicon M580 ePAC	<ul style="list-style-type: none"> <li>● Primary voltage: 100-240V</li> <li>● Local digital I/O processor capacity: 1024 I/O</li> <li>● Local analog I/O processor capacity: 256 I/O</li> </ul>
AH5775 Driver	<ul style="list-style-type: none"> <li>● Operating voltage: 2.5 - 18V</li> <li>● “Applications: 5V/ 12V / 15V min. BLDC cooling fan</li> <li>● Maximum continuous output current: 300mA</li> </ul>
Panaflo FBA08T12L Fan	<ul style="list-style-type: none"> <li>● Operating voltage: 7-13.8V</li> <li>● Rated current: 79 mA</li> <li>● Nominal speed: 2000 rpm</li> </ul>



## Chapter 4: Design

The PLC HVAC system model is built up of three main sections: the heating side, the PLC itself, and the cooling side. The two main areas of design concern are the heating and cooling side, as the PLC unit is not flexible when deciding components. These two subsections are broken down in Figure 4-1 and Figure 4-2.

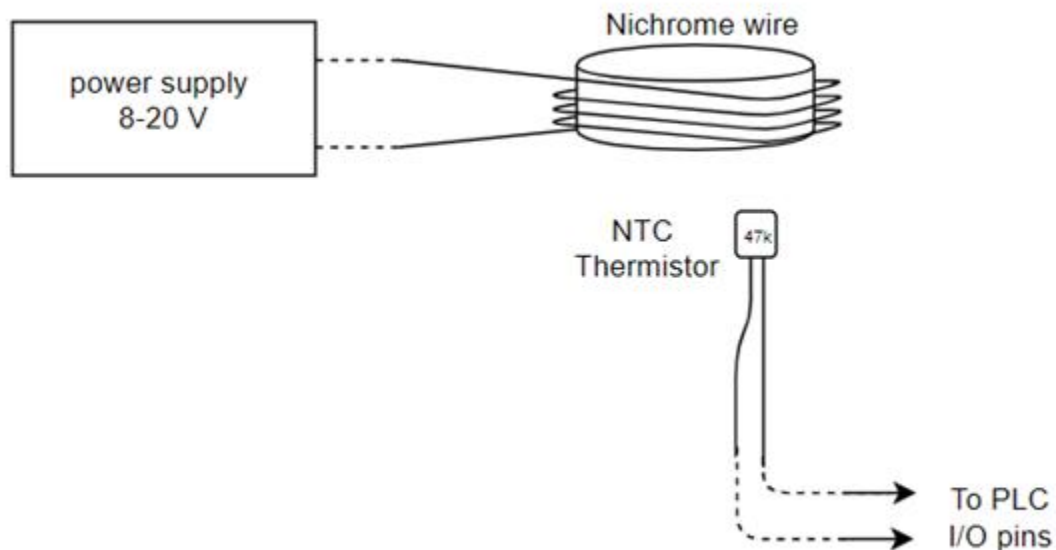

Figure 4-1: Heating Side Design

The heat sensing focuses on reading temperature values from a “variable temperature source”, which in our case is a variable power supply with nichrome wire. The specifications of the heat sensing side required a 0-20V swing on the power supply, which gives a range of temperatures achievable given the wire gauge. We chose 24-gauge wire, which corresponds to  $\sim 1.6\Omega/\text{ft}$ . Based on the desired range of temperatures, a NTC thermistor was chosen to encode temperature as resistance, which can be read by the PLC’s analog I/O. This allows for the PLC

logic, written using the functional block programming style, to output to the fan drivers based on current temperature sensed by the thermistor.

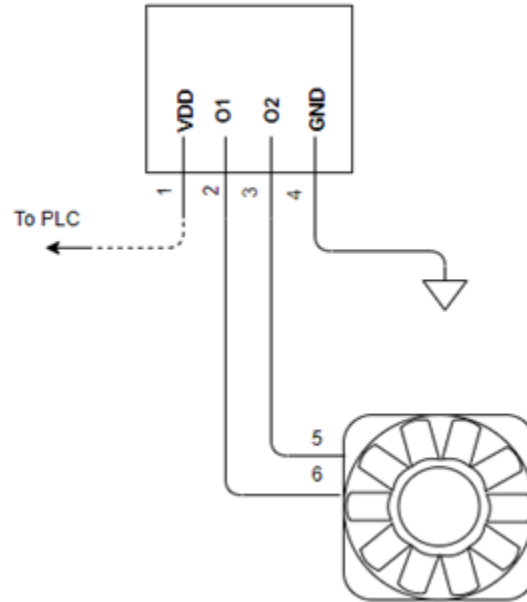

Figure 4-2: Cooling Side Design

Table 4-1: Cooling Side Pins

Pin Number	Pin Name	Description
1	VDD	Power supply input
2	O1	Output drive sourcing & sinking pin
3	O2	Output drive sourcing & sinking pin
4	GND	Ground
5	Red +	Fan positive wire
6	Black -	Fan negative wire

The cooling side consists of 3 fans which run off a set of drivers. The provided computer fans, the Panaflo FBA08T12L Fans, are brushless fans with an operating voltage of 7-13.8 volts and rated current of 79mA. Figure 4-3 shows the fan. Because of these relatively high current specifications, the fans cannot be wired directly to the PLC unit, making a driver necessary. The driver component chosen is a simple single-phase motor driver. It is a single-chip solution for driving brushless direct current fans. Common applications for this driver include 5V/ 12V/ and 15V BLDC cooling fans, which the Panaflo fans fall under. In addition to supplying the necessary current to the fans, these drivers allow for variable speeds in the fans. For a 12V nominal motor, changing the supply voltage from 12 V to 6V will cut the speed by 50%. The driver was also selected for its simple implementation. As seen in Figure 4-2, there are only four pins on the driver, two to power and ground it, and two to connect to the fan.



Figure 4-3: Cooling Side Fan

Attached at the back end of the cooling unit will be LEDs for every fan and driver pair, three of each. This generic LED will be used as an indicator for abnormalities. A person monitoring the system can determine whether the fans are working properly by seeing if the LED is on or off.

Table 4-2 lists a bill of materials for all the components necessary for the HVAC PLC system designed. Table 4-3 lists the associated datasheets for some of the components.

Table 4-2: Bill of Materials and Purchase Links

Item	Description	Link	Price (\$)	Count	Extended Price (\$)
Modicon M580 ePAC	Ethernet Programmable Automation Controller	<a href="#">Schneider M580</a>	0	6	0
PC Fan	Panaflo FBA08T12L 79mA 12V	(already acquired)	0	24	0
Thermistor	THERMISTOR NTC 47KOHM 4050K BEAD	<a href="#">Digikey</a>	0.45	12	5.40
Nichrome Wire	Nichrome 80 - 100' - 24 Gauge Resistance Wire	<a href="#">amazon</a>	8.49	6	50.94
LED	set of 300 LEDs for fan status	<a href="#">amazon</a>	8.87	1	8.87
Fan Drivers	IC MOTOR DRIVER 2.5V-18V 300mA TO94	<a href="#">Digikey</a>	0.57	24	13.68
				<b>TOTAL PRICE (\$)</b>	78.89

Table 4-3: Component Datasheets

PC fan datasheet	<a href="https://datasheetspdf.com/pdf-file/613208/ETC/FBA08T12L/1">https://datasheetspdf.com/pdf-file/613208/ETC/FBA08T12L/1</a>
Thermistor	<a href="https://www.murata.com/~media/webrenewal/support/library/catalog/products/thermistor/ntc/r44e.ashx?la=en-us">https://www.murata.com/~media/webrenewal/support/library/catalog/products/thermistor/ntc/r44e.ashx?la=en-us</a>
Nichrome wire	<a href="https://temcoindustrial.com/temco-rw0407-nichrome-80-wire-100-ft.html">https://temcoindustrial.com/temco-rw0407-nichrome-80-wire-100-ft.html</a>
Fan drivers	<a href="https://www.diodes.com/assets/Datasheets/AH5775.pdf">https://www.diodes.com/assets/Datasheets/AH5775.pdf</a>

## Chapter 5: Simulation

Because of hardware constraints during the COVID-19 pandemic, the HVAC system will be modeled and simulated. The simulation software used will be the Modicon M580's main programming software, Unity Pro XLS by Schneider Electric. Unity Pro is a convenient tool for testing the system because it allows the user to write their desired commands for the system, simulate the program, and then apply it to the PLC. This means, with limited hardware, the only step that is skipped is the application of the program to the PLC.

The HVAC simulation in Unity Pro will make use of Function Block Diagrams as its programming language. The steps to setting up a Function Block Diagram and running a simulation are:

1. Open Unity Pro XLS, under the File tab, create a new project or press control + N.
2. Under Modicon M580 options, select the "BME P58 4040" option and click OK
3. In the project browser, expand the Program file → Tasks → MAST → right click on Sections. And click New section....

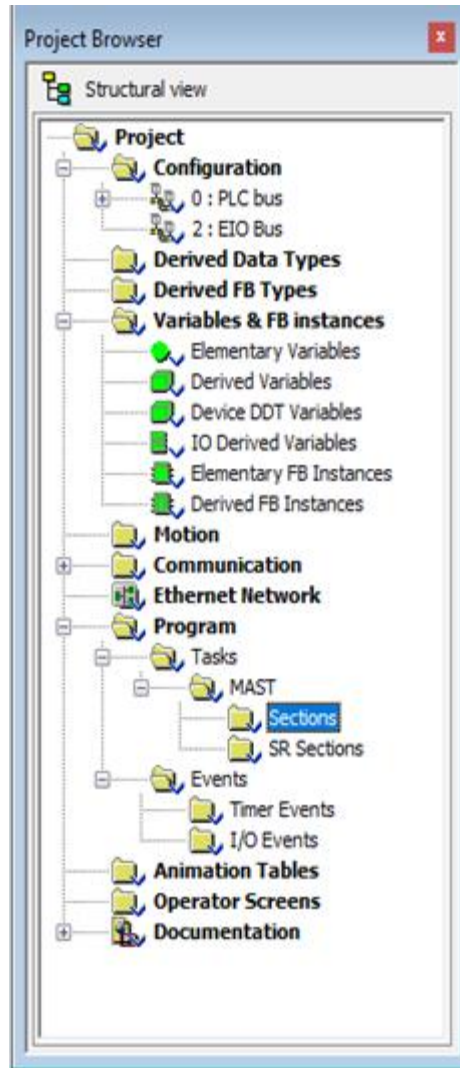

Figure 5-1: Simulation set up- step 3: New Simulation files

4. Name the file, and from the Language drop down menu choose FBD. After clicking OK, the file is ready to be edited.
5. To create function blocks right click on the window and select Data Selection.

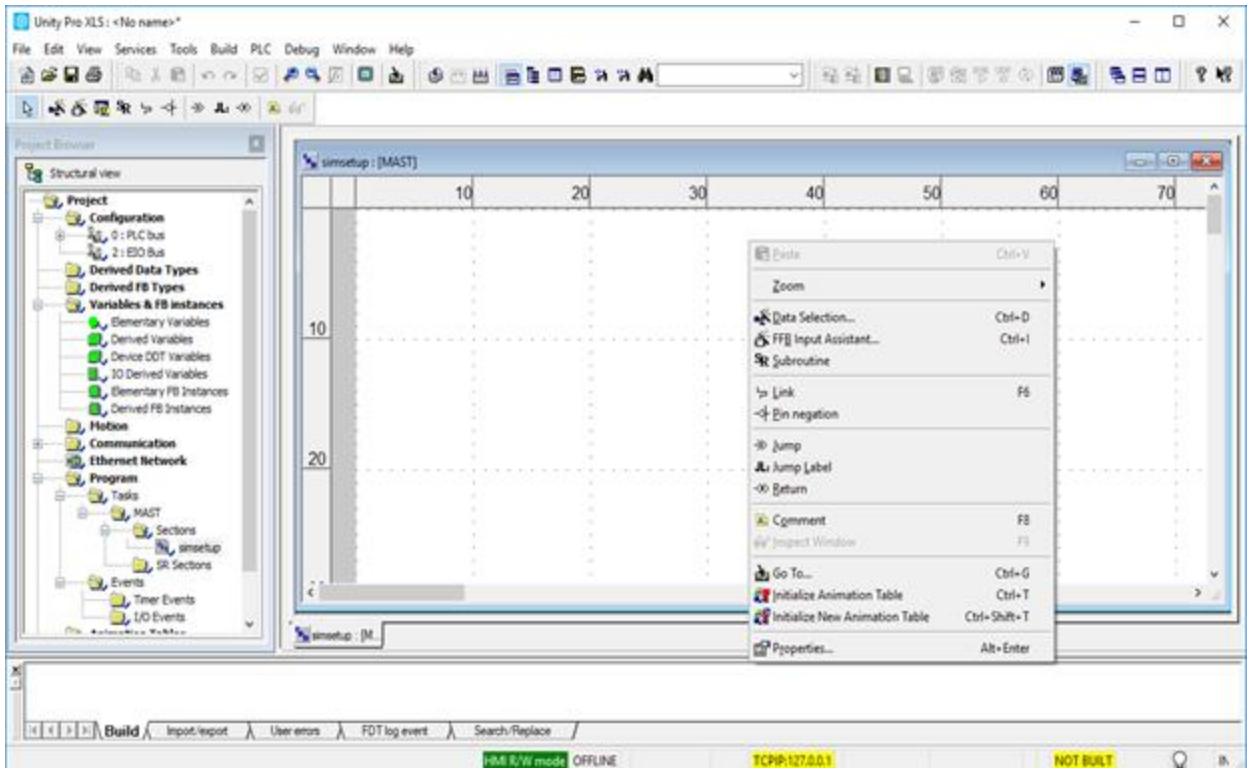

Figure 5-2: Simulation setup step 5: Inserting new blocks

6. From the text box, type the desired function block name (AND, OR, etc.) Or click on the ellipses → Function and Function Block Types tab → <Libset V13.0> and search for the function block.



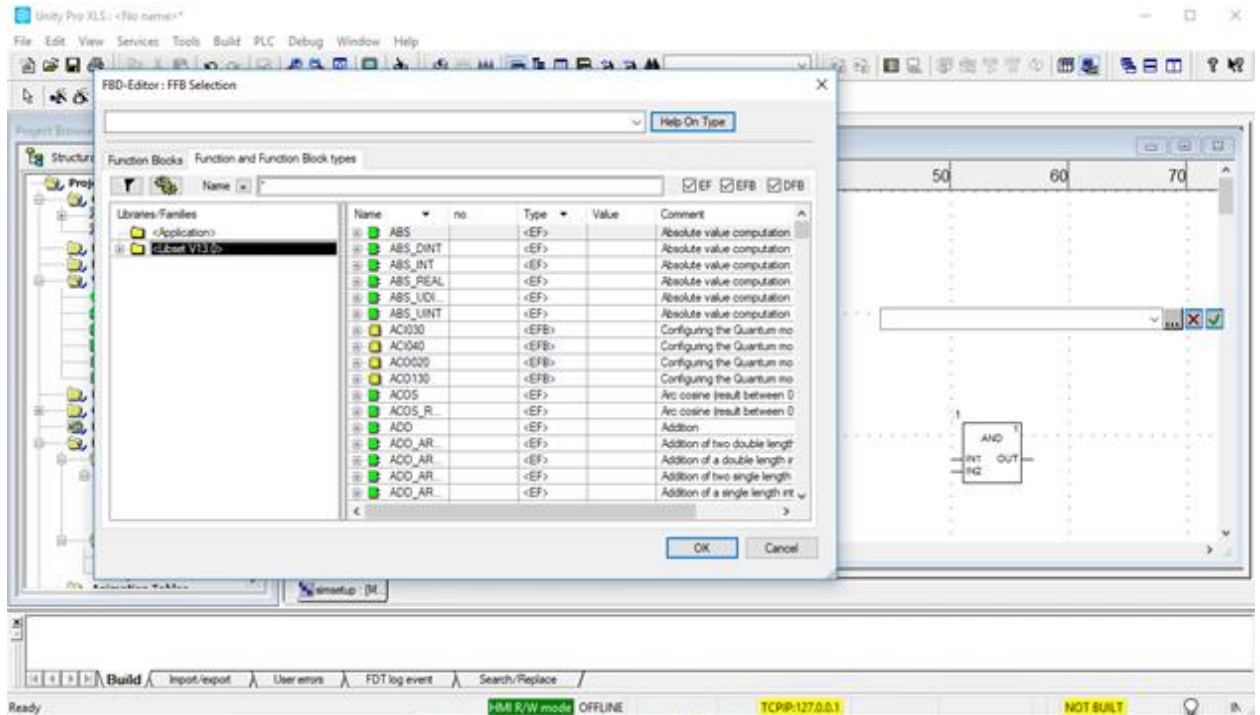

Figure 5-3: Simulation setup step 6: Block type selection

7. After making the program with function blocks, click the PLC tab → simulation mode → connect → transfer project to PLC
8. Then under the build tab click build project
9. Under PLC tab click run
10. Right click animation tables → new table → insert
11. Variables can be put in an animation table, where their values are dynamic and can be set to any value. This animation table serves as an area to debug the FBD and ensure the system's performance is adequate.

The screenshot shows a software interface with a table of simulation variables. The table has four columns: Name, Value, Type, and Comment. The 'Name' column lists various variables like FAN1, FAN2, FAN3, FANOUT1, FANOUT2, FAULT1FAN, FAULT2FAN, FAULT3FAN, FAULT12FAN, LED1, LED2, LED3, T25, T50, T75, T100, and TEMPERATURE. The 'Value' column shows binary values (1 or 0) for most, and 120 for TEMPERATURE. The 'Type' column shows EBOOL for most and INT for TEMPERATURE. The 'Comment' column is empty for all entries.

Name	Value	Type	Comment
FAN1	1	EBOOL	
FAN2	1	EBOOL	
FAN3	0	EBOOL	
FANOUT1	1	EBOOL	
FANOUT2	1	EBOOL	
FAULT1FAN	0	EBOOL	
FAULT2FAN	0	EBOOL	
FAULT3FAN	0	EBOOL	
FAULT12FAN	0	EBOOL	
LED1	0	EBOOL	
LED2	0	EBOOL	
LED3	0	EBOOL	
T25	1	EBOOL	
T50	1	EBOOL	
T75	1	EBOOL	
T100	1	EBOOL	
TEMPERATURE	120	INT	

Figure 5-4: Simulation setup step 11: Inserting variables and changing values

Figure 5-5 shows the function block diagram used to simulate the HVAC system. It uses an incoming temperature value and based on the level turns on the corresponding number of fans. If any of the faults for a main fan are triggered, the backup fan should turn on when the original fan would have.

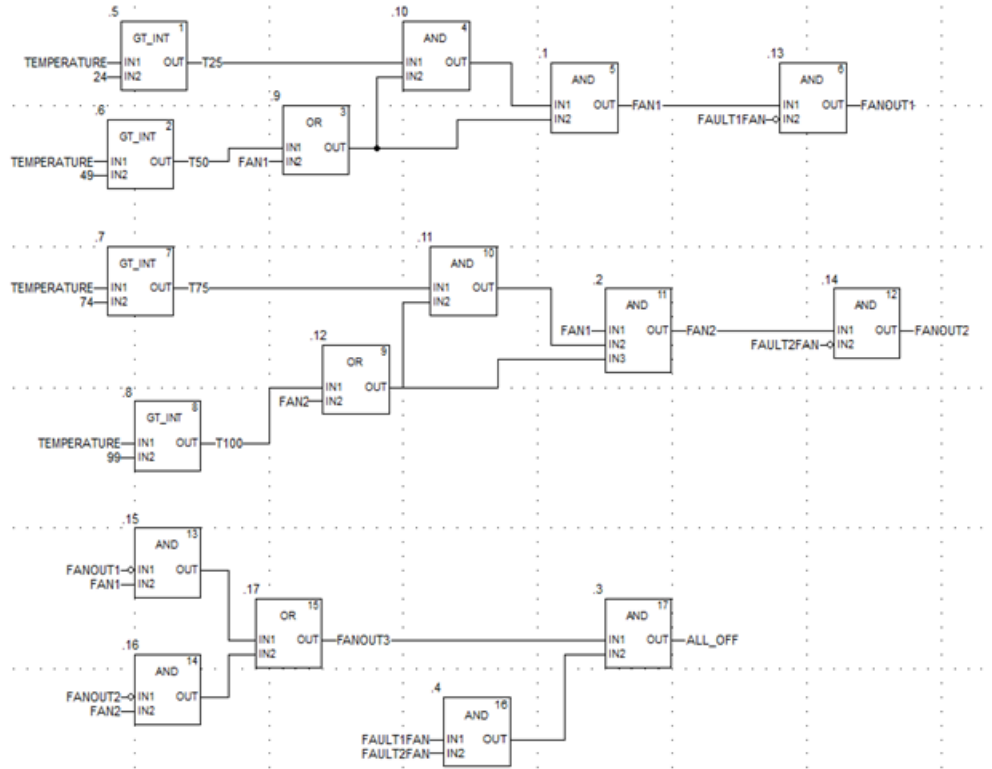

Figure 5-5: HVAC System Function Block Diagram for Simulation

Table 5-1 shows a simulation of multiple temperature values without any faults, the expected results, and simulated results.

Table 5-1: Simulation test without faults

Temperature (°C)	Increasing or decreasing towards value?	Expected results	Do simulation results match?
20	Increasing	All three fans are off	Yes
45	Increasing	All three fans are off	Yes
50	Increasing	Fan 1 On	Yes
80	Increasing	Fan 1 On	Yes
100	Increasing	Fan 1 and 2 On	Yes
90	Decreasing	Fan 1 and 2 On	Yes
75	Decreasing	Fan 1 on Fan 2 turns off	Yes
40	Decreasing	Fan 1 on Fan 2 off	Yes
25	Decreasing	Fan 1 turns off Fan 2 off	Yes

From the simulation test shown in Table 5-1, without any faults, the system works as planned.

When increasing, the temperature thresholds of 50°C and 100°C turn on fan 1 and fan 2, respectively. When decreasing, the notable thresholds are 75°C and 25°C. At these values, fan 2 and fan 1 should turn off, respectively. Because no faults have been tripped, fan 3 remains off the entire time. Figure 5-6 and Figure 5-7 show the simulation results for the 50°C and 90°C that appear in Table 5-1.

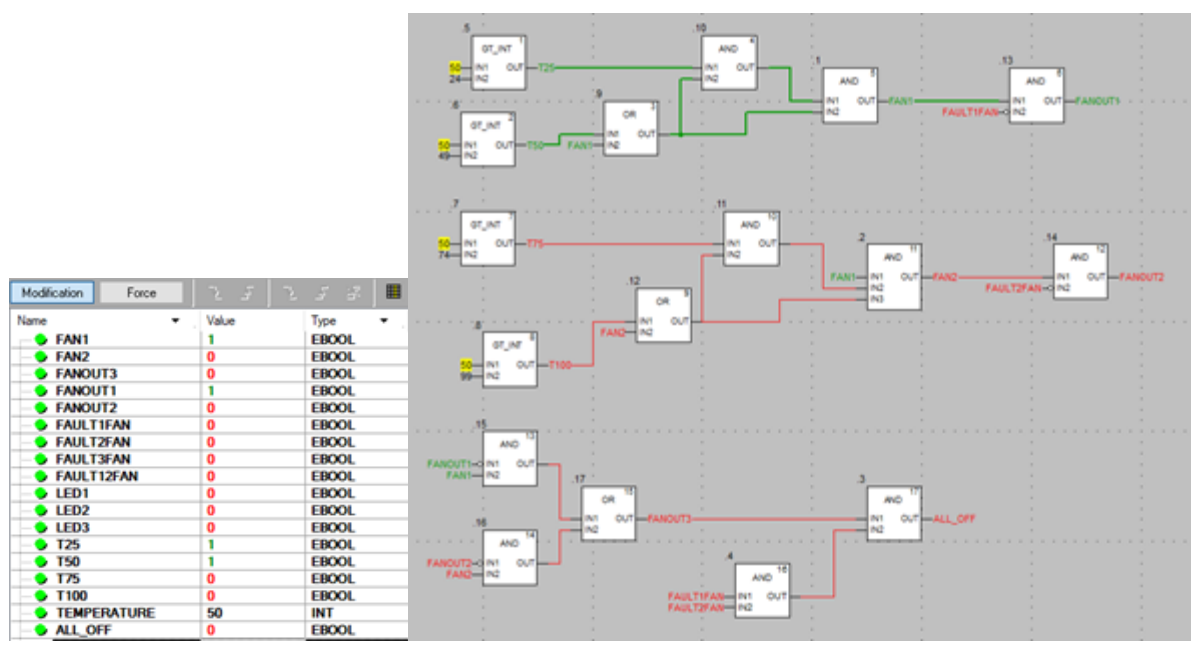

Figure 5-6: No fault simulation of increasing to temperature of 50°C

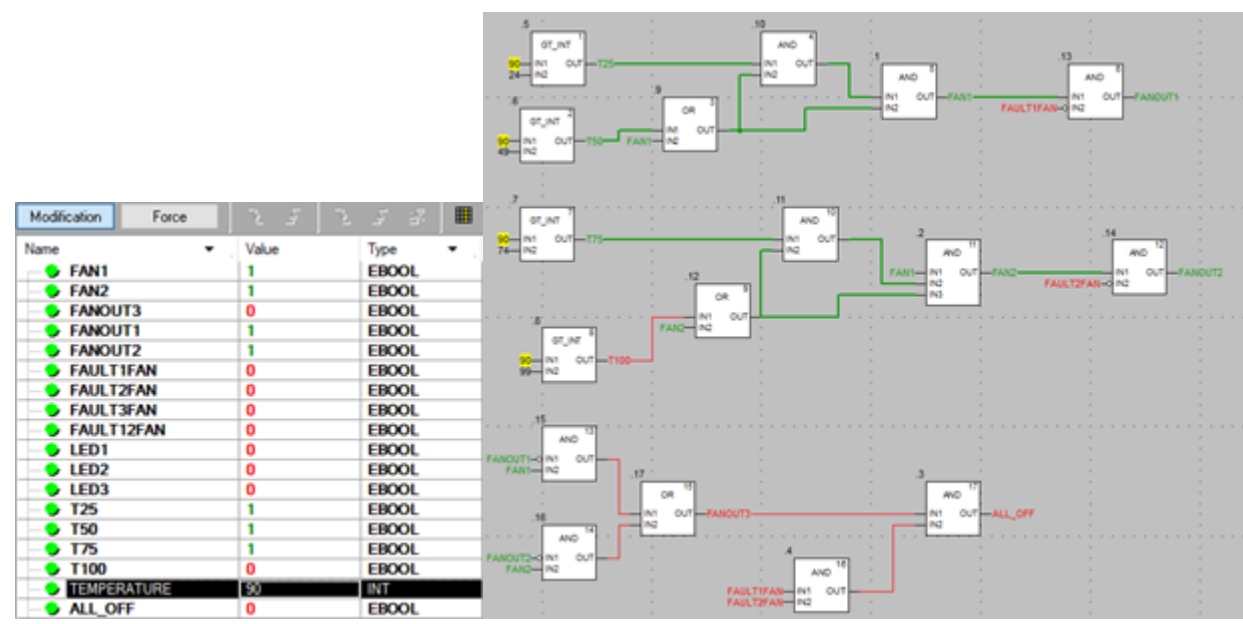

Figure 5-7: No fault simulation of decreasing to temperature of 90°C

Table 5-2 displays test results for the same temperatures as test 1 but includes either fault 1 or fault 2 being triggered. This tests to make sure that fan 3 activates should one of the other two fail.

Table 5-2: Simulation Testing Faults

Temperature (°C)	Increasing or decreasing towards value?	Fan fault triggered	Expected fan 1	Expected fan 2	Expected fan 3	Do simulation results match?
20	Increasing	Fan 1	off	off	off	yes
45	Increasing	Fan 2	off	off	off	yes
50	Increasing	Fan 1	off	off	on	yes
80	Increasing	Fan 1	off	off	on	yes
100	Increasing	Fan 2	on	off	on	yes
90	Decreasing	Fan 1 & 2	off	off	on	yes
75	Decreasing	Fan 1	off	off	on	yes
40	Decreasing	Fan 1	off	off	on	yes
25	Decreasing	Fan 1	off	off	off	yes

Because fan 2 only turns on after reaching 100°C, the fault for fan 1 will primarily be used to test the fault system. In all scenarios, fan 3 takes the role of a fan that has had its fault trigger. The status the original fan has translates to the status that fan 3 takes on as well. This is seen by comparing Table 5-1 and Table 5-2. We see at 45°C, that fan 2 is faulted, so fan 3 takes its role, and because fan 2 should be off, fan 3 remains off. On the other hand, at 100°C, when fan 2 should turn on, since fan 2 is once again faulted, fan 3 takes its role, and turns on. In the case that both faults are triggered, fan 3 will turn on if either fan should be on. However, at this point, the program should recognize the HVAC system will not work as intended and turn off the entire system. Figures 5-8 and 5-9 show simulation results including the fan faults for the 80°C and 90°C in Table 5-2.

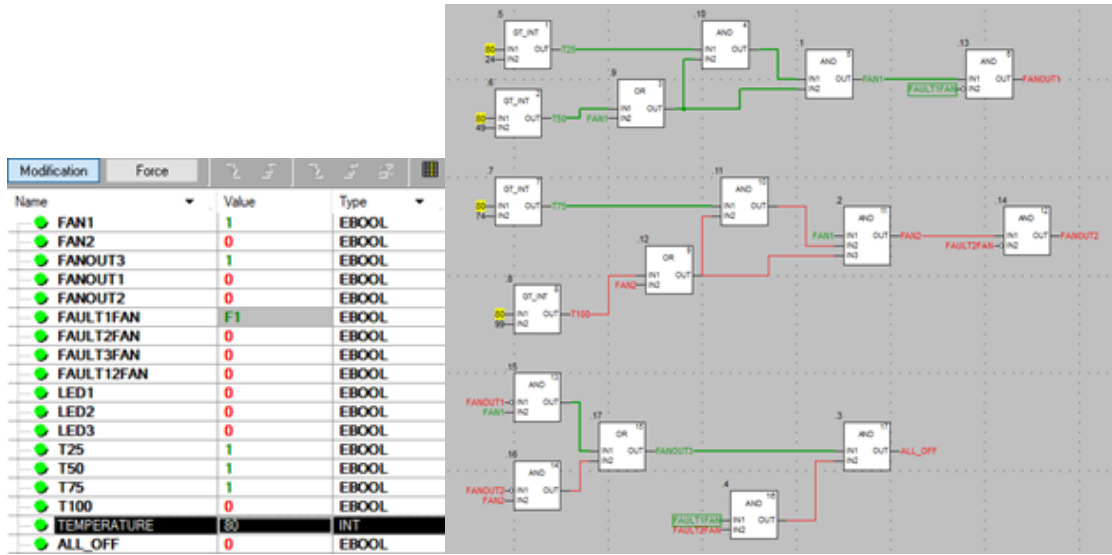

Figure 5-8: Simulation Increasing to temperature 80°C with fault 1 triggered

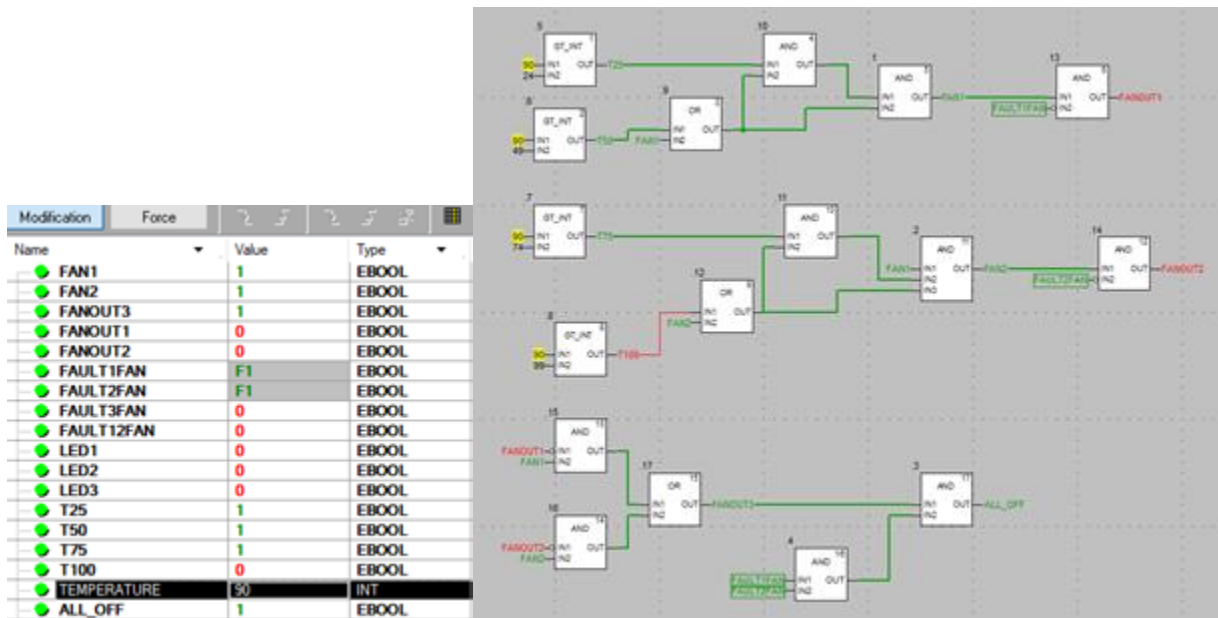

Figure 5-9: Simulation Decreasing to temperature 90°C with fault 1 and 2 triggered

## Chapter 6: Conclusion

This project consists of developing a variable frequency drive (VFD) lab experiment for a new Electrical Engineering lab course at Cal Poly SLO. The usage of VFDs is explored with a Heating, Ventilation, and Air Conditioning system utilizing the controllability of the Modicon M580 PLC. In the experiment, students will use a different programming language, moving on from ladder logic in their previous experiments. They will learn to program the PLC with function block diagrams in order to control the system and keep the temperature regulated, following the parameters given to them. This is a common design for closed-loop HVAC systems, so exposing students to a commonly seen PLC application is greatly beneficial.

The original design of the experiment uses a heating side, consisting of a heating element and temperature sensor, and a cooling side, fans, and drivers. The two are connected to Modicon M580, allowing the PLC to monitor the situation and adjust outputs. Hardware constraints led to limitations in the project scope, so simulations and software tests were added to the project to progress. Running simulations and tests show that the design of the system works accordingly. Modeling the system showed us potential problems that could arise, and with that knowledge we could change the system to accommodate any revisions.

The next step this project would take to improve the project would be to move from the simulation to hardware. Buying the physical components for the HVAC system to compliment the Modicon M580, and then connecting it together would allow the simulation results to be tested experimentally. Expanding the scope of the project could include altering the parameters for the design and coding of the heating and cooling, requiring usage of more fans or more complex algorithms and coding. The final extension to this project would be producing a lab



procedure for a lab manual along with a copy of desired results from the experiment for instructor usage. This would allow for this lab to be integrated into a PLC lab class, letting students get hands-on learning with industry standard programmable logic controllers.

### Appendix A: Scheduling

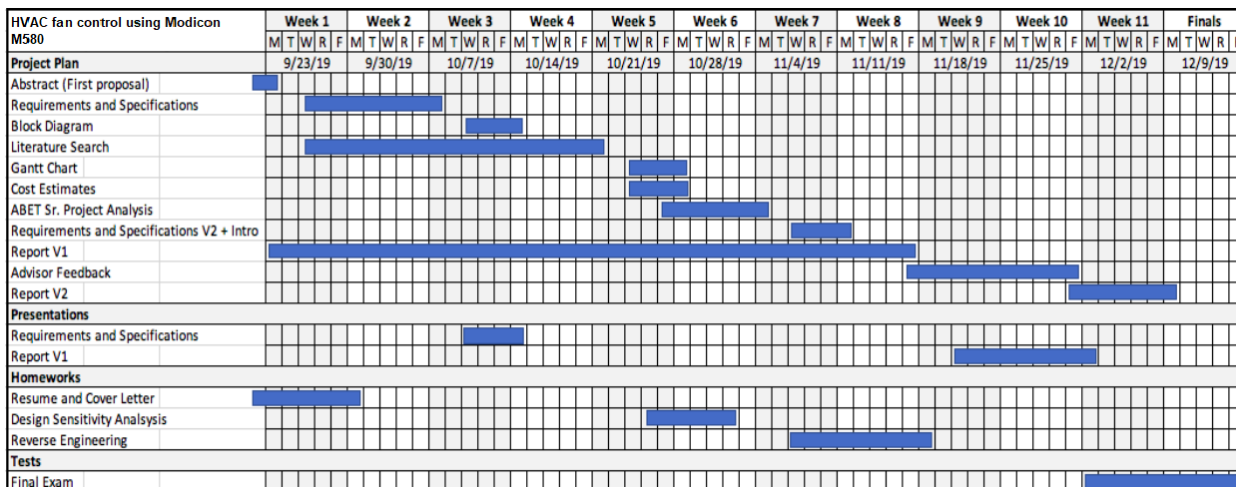

Figure A-1: Fall Quarter 2019 Gantt Chart

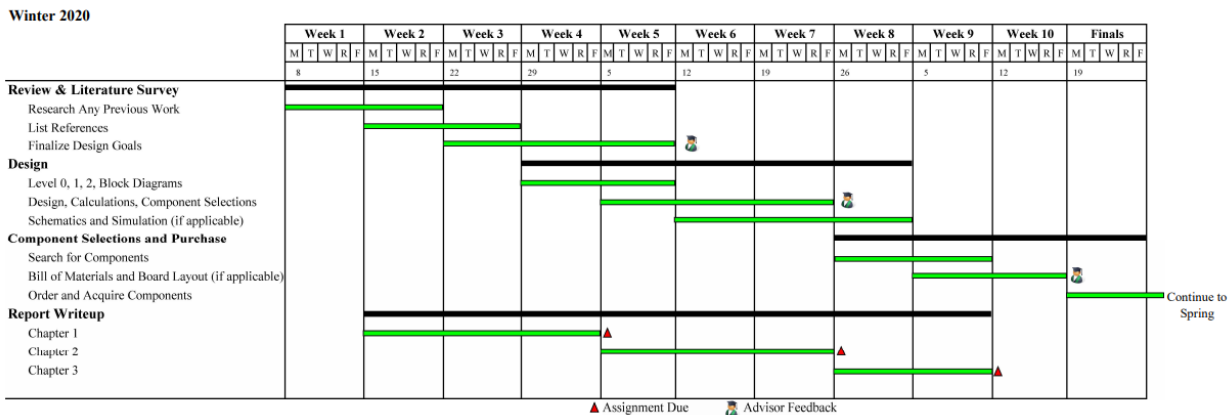

Figure A-2: Winter Quarter 2020 Gantt Chart

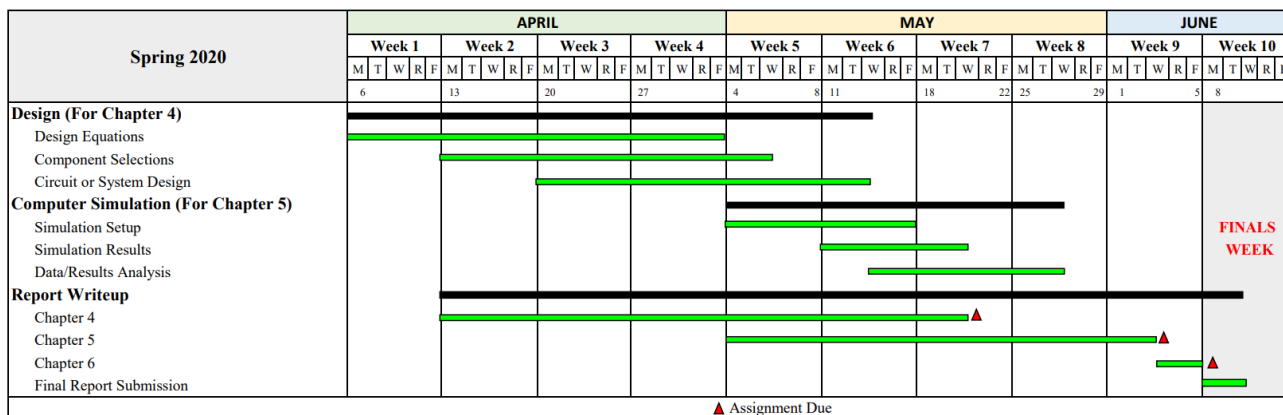

Figure A-3: Spring Quarter 2020 Gantt Chart

## Appendix B: Bill of Materials

### Table B-1: Bill of Materials for Current Project

	A	B	C	D	E
1	Item	Description	Price	Count	Extended Price
2	Modicon M580 ePAC	Ethernet Programmable Automation Controller		6	0
3	PC Fan	Panaflo FBA08T12L 79mA 12V		24	0
4	Thermistor	THERMISTOR NTC 47KOHM 4050K BEAD	0.45	12	5.40
5	Nichrome Wire	Nichrome 80 - 100' - 24 Gauge Resistance Wire	8.49	6	50.94
6	LED	set of 300 LEDs for fan status	8.87	1	8.87
7	Fan Drivers	IC MOTOR DRIVER 2.5V-18V 300mA TO94	0.57	24	13.68
8				<b>TOTAL PRICE</b>	<b>78.89</b>

### Table B-2: Bill of Materials for Previous Project

	A	B	C	D	E	F
1	Product Code	Description	Supplier	Cost Per Unit (\$)	Quantity	Total (\$)
2	P584040	Modicon M580 P584040	Schneider Electric		6	0.00
3	CPS3500	CPU PSU	Schneider Electric		6	0.00
4	Phaseo ABL8REM24050	HMI PSU	Schneider Electric		6	0.00
5	DDI1602	Dig 16I 24 Vdc Sink	Schneider Electric		6	0.00
6	DRA0805	Dig 8Q Isolated Relays	Schneider Electric		6	0.00
7	AMI0410	Ana 4 U/I Inputs Isol High Speed	Schneider Electric		6	0.00
8	AMO0410	Ana 4 U/I Out Isolated	Schneider Electric		6	0.00
9	HMIS85/HMIS5T	Touchscreen Monitor	Schneider Electric		6	0.00
10	TCSESU053FN0	Ethernet Switch	Schneider Electric		6	0.00
11	B01AUQ33LG	Tyrone Gooseneck Tablet Stand	Amazon	20.99	6	125.94
12	AB 1489-M1C030	1P 3A Circuit Breaker	Royal Industrial Solutions	55.84	6	335.04
13	AB 1489-M1C016	1P 1.6A Circuit Breaker	Royal Industrial Solutions	55.84	6	335.04
14	4008190046019	DIN rail Weidmüller 35X7.5/LL 2M	Automation 24	15.21	7	106.47
15	AB 1492-J3	Terminal Block	Royal Industrial Solutions	0.78	140	109.20
16	AB 1492-EBJ3	Terminal Block End Barrier	Royal Industrial Solutions	0.56	14	7.84
17	AB 1492-EAJ35	Terminal Block End Anchor	Royal Industrial Solutions	1.50	14	21.00
18	AB 1492-JG3	Gnd Terminal Block	Royal Industrial Solutions	3.92	12	47.04
19	FRT FREIGHT IN AB	Shipping and Handling	Royal Industrial Solutions	8.95	1	8.95
20	<b>Note:</b> Donated parts not included in final cost				<b>Grand Total:</b>	<b>\$1,096.52</b>

## Appendix C: ABET Senior Project Analysis

**Project Title:** HVAC Fan Control Using Modicon M580

**Students:** Kevin Shipp, Anthony Tyler

**Advisor's Name:** Professor Taufik

### Summary of Functional Requirements

- HVAC system containing PLC, fans, and heat source
- Programmable with Function Block Diagrams
- Develop experiment for student exposure to HVAC systems

### Primary Constraints

- 3-hour lab
- Minimize cost
- Deliver class objectives in hands-on lab format

### Economic

Various economic impacts resulting from this project are shown in the table below.

Table C-1: Economic Impacts

<b>Human Capital</b>	People are needed to set up communication between the PLCs and the VFD in order to control the VFD and use it
<b>Financial Capital</b>	The PLCs, VFD, input/output modules, and programming software are all donated from Schneider Electric, and laboratory testing equipment is provided by Cal Poly, so the only cost is labor.
<b>Manufactured or Real Capital</b>	The end result of this project is to utilize the PLCs and VFD in an experiment, and to create an accompanying lab manual.
<b>Natural Capital</b>	PLCs typically contain a plastic casing, resin for the circuit boards, metal for various components, etc. These are limited to what can be produced using the planet's resources.

### Commercial Manufacturing

This project creates a lab experiment and is not expected to be commercially manufactured. However, the equipment utilized is mass produced, so costs for the PLCs and software are shown below.

Table C-2: Commercial Manufacturing

<b>Estimate</b>	<b>Cost</b>	<b>Justification</b>	<b>Condition</b>
# of Devices Sold Per Year	~6 million	\$9B profit/\$1500 purchase price	Hardware and software
Manufacturing Cost Per Device	N/A	Not information that is released by manufacturers.	
Purchase Price for Each Device	~\$1500	Software is \$1000+ and hardware ranges from \$100-\$1000	Hardware and software (1-year software license, not including yearly renewal fees/increases)
Yearly Profit	~\$9 billion	Global statistics	Globally (not just Schneider)
Cost for User to Operate Device, Per Unit Time	~\$385	Minimum wage in SLO County is \$11	30 - 40 hours for introductory PLC programming course

### Environmental

The materials used and the by-products caused by manufacturing can cause a detriment to the environment if on a large enough scale. Although the scope of this project alone is not enough to significantly affect the environment, since the equipment used is mass produced, this project indirectly impacts the environment in a negative way.

This project directly uses electricity to power all the equipment, and indirectly uses various materials to manufacture the different parts. The reason the materials used to manufacture the equipment is considered indirect is because the PLCs and VFD were donated by Schneider Electric; this project is focused on using that equipment to create an experiment.

This project does not significantly improve or harm the natural resources and ecosystem services, or impact other species in a direct way.

### Manufacturability

The PLC industry is a multi-billion-dollar market, so it can be inferred that there are no major issues associated with manufacturing. Not only that, but the materials used are also relatively commonplace and abundant. The hardware for the PLC is the simpler aspect of the system; most of the money (for both the supplier and consumer) comes from the software developed. However, no manufacturing needs to be done, since all equipment will be in the lab, accessible for students and manufacturing does not cover the scope of the project.

### Sustainability

There should not be any issues with maintaining the completed system, as it will be stored indoors away from outside weather conditions (it will be in a lab in the EE building). There is a long lifecycle for associated components in the lab. (e.g. the M580's life cycle is over 20 years) Once connected, the individual components should not need to be disconnected, and can be left alone. This project does not directly impact the sustainable use of resources, as the project itself is to create an experiment.

Upgrades to improve the design of the project cannot be determined at this time, since the project has yet to be completed. Along that line, the challenges that came with upgrading the design are also unknown at this time.

### Ethical

It would be difficult to misuse a lab experiment created for future EE students to introduce them to PLCs, and since the equipment will be reused between sections, the ethical aspect of manufacturing will not be an issue.

This project is in accordance with points five and six of the IEEE Code of Ethics, and the points are listed below, respectively:

- to improve the understanding by individuals and society of the capabilities and societal implications of conventional and emerging technologies, including intelligent systems.
- to maintain and improve our technical competence and to undertake technological tasks for others only if qualified by training or experience, or after full disclosure of pertinent limitations.

### Health and Safety

There are no health concerns associated with the design, manufacture, or use of the project. Standard Cal Poly EE Lab guidelines are to be adhered to at all times.

### Social and Political

There are minimal social or political issues associated with the design, manufacture, or use of the project.

### Development

In addition to Schneider Electric's PLC workshop, students will spend time on their own familiarizing themselves with the functionality of PLCs and the programming syntax as well as variable frequency drives. Studying the systems and the interfacing between the two is expected in order to understand the full scope of the project.

A literature search of sources that are expected to aid the students is provided in the "works consulted" section.

## References

- [1] “History of the PLC.” automationdirect.com. <https://library.automationdirect.com/history-of-the-plc/> (Accessed: Jan 30, 2020).
- [2] “Modicon History.” se.com. <https://www.se.com/in/en/about-us/events/modicon.jsp> (Accessed: Jan. 30, 2020).
- [3] S. Gates. “A Beginner’s PLC Overview, Part1 of 4: Introduction to PLCs.” Automation.com. <https://www.automation.com/automation-news/article/a-beginners-plc-overview-part-1-of-4-introduction-to-plcs> (Accessed: Jan. 30, 2020).
- [4] M. Budimir. “What are IEC 61131-3 and PLCopen?” designworldonline.com <https://www.designworldonline.com/what-are-iec-61131-3-and-plcopen/> (Accessed: Jan. 30, 2020).
- [5] “What are PLC DDC and HVAC Controller's and where are they used?” meee-services.com. <https://www.meee-services.com/what-are-plc-ddc-and-hvac-controllers-and-where-are-they-used/> (Accessed: Jan. 30, 2020)
- [6] “Controlling HVAC System with Industrial PLC Arduino.” industrialshields.com. <https://www.industrialshields.com/case-study-hvac-control-and-monitoring-with-arduino-plc-based> (Accessed: Feb. 18, 2020).
- [7] S. Bituen, M. Campos, N. I. Khan. “Industry Automation and Controls Lab.” digitalcommons.calpoly.edu. <https://digitalcommons.calpoly.edu/eesp/448/> (Accessed: Feb. 18, 2020).
- [8] Bhavesh “PLC Program for Fan Control Unit System for Industry.” instrumentationtool.com. “<https://instrumentationtools.com/plc-program-for-fan-control-unit-system-for-industry> (Accessed Feb. 18, 2020)
- [9] P. Rakshe. “Programmable Logic Controller for HVAC Application.” semanticscholar.org. <https://pdfs.semanticscholar.org/c41f/1b110bf5927893c143ac5d5387860060d566.pdf> (Accessed Feb 18, 2020)
- [10] Purdy, A. & Barrett, S. & Wright, Cameron. (2011). Hands on programmable logic controller (PLC) laboratory for an industrial controls course. 21. 28-36.
- [11] A. Megri, “Development of a Laboratory Set-up Interfacing Programmable Logic Controller (PLC), Variable Frequency Drive (VFD) and HVAC Applications,” *2015 ASEE Annual Conference and Exposition Proceedings*.



Megri's paper provides insight on the development of laboratory set-up interfacing between programmable logic controllers and a variable frequency drive. This interface and the laboratory set up matches what the senior project intends to do, making it a valuable source. Ahmed Megri has a PhD from INSA at Lyon. He has taught for many years and many courses, so he understands how to develop a lab course. And has written over 100 journal and conference papers.

- [12] D. Ding, "PLC control system design of large gantry planer based on variable-frequency drives," *2011 Second International Conference on Mechanic Automation and Control Engineering*, Jul. 2011.

Ding's paper covers PLCs, VFDs, and the control system needed between the two. This information is necessary to get the two to communicate. Ding has written 4 IEEE papers all with a few hundred full text views. He works at the EE department in Shanghai Dianji University and has written textbooks that are used at the university.

- [13] J. Jiang and X. Zhang, "Variable frequency speed-regulation system of elevator using PLC technology," *2011 3rd International Conference on Advanced Computer Control*, 2011.

Jiang and Zhang cover variable speed regulation and VFDs using PLC technology, which is the same topic as the project. Author Zhang works in Hebei China at the Science and Technology on Electro-optical information security control laboratory, and performed all the data gather with Jiang. They reference all their sources, many which cover VFDs, and acknowledge their professors that helped them write the thesis paper which was published by IEEE.

- [14] K. T. Erickson, "Programmable logic controllers," *IEEE Potentials*, vol. 15, no. 1, pp. 14–17, Feb. 1996.[Online]. Available: IEEE Xplore, <https://ieeexplore-ieee-org.ezproxy.lib.calpoly.edu/document/481370/authors#authors>.

This source is an IEEE article on the architecture of programmable logic controllers. The article details the ladder logic inside PLCs, along with diagrams of the logic. The article has been cited by 37 other papers, 25 from IEEE. It has been cited in a patent and sources textbooks for reference.

- [15] Ludington, D., Guo, F., Kowalski, J. and Pellerin, R. (1999). *Vacuum level control system using variable frequency drive*. US5960736A.

This patent covers a vacuum pump that is controlled by a variable frequency drive. The Variable frequency drive and how it operates is important in understanding how to integrate it with the PLC. The patent is from 1997 and is currently held by the Cornell Research Foundation so it contains valuable information worth being held for research. It's been cited by 30 people.

- [16] M. Arrofiq and N. Saad, "PLC-based fuzzy logic controller for induction-motor drive with constant V/Hz ratio," *2007 International Conference on Intelligent and Advanced Systems*, Nov. 2007.

This paper covers PLCs as a fuzzy logic controller for motor speed control. The motor controlling and PLC logic is important information for the project and the unfamiliarity with Fuzzy logic is important information for understanding PLCs. The author won an award with the paper and acknowledges the support of Universiti Teknologi PETRONAS.

- [17] Petruzella, F. (2016). *LogixPro PLC lab manual for use with Programmable logic controllers*. 5th ed. McGraw-Hill Education.

This book covers labs that use PLCs. It will be helpful for the formatting of our own lab manual and procedure. It is a published lab manual that is used in classrooms making it credible and valuable information in our own lab.

- [18] Schneider-electric.us. (2019). Modicon M580, Hardware Reference Manual | Schneider Electric. [online] Available at: <https://www.schneider-electric.us/en/download/document/EIO0000001578/> [Accessed 20 Oct. 2019].

This is Schneider electronics data sheet for the Modicon M580 which is what is used in the lab that is being made. The data sheet will provide information necessary for creating the lab. This Schneider data sheet is reliable information because they are the ones who made the product so their data sheet should be accurate.

- [19] Serhane, A., Raad, M., Raad, R. et al. *SN Appl. Sci.* (2019) 1: 924. <https://doi.org/10.1007/s42452-019-0860-2>

This paper covers the security concerns of PLCs and the vulnerability when integrated with complex system. This information is important for the connection between the VFD and the PLC. The authors published their paper in Springer Internationals journal this past July and credibility comes from the 34 sources they reference in their paper.

- [20] W. Bolton, *Programmable logic controllers: an introduction*, 2nd ed. Oxford, Boston, MA: Newnes, 2006.

This book introduces PLCs, with examples and programming problems designed to cover technology from a range of manufacturers. It provides working knowledge for degree students and engineers that wish to know more on PLCs. According to Google Scholar, this book has been cited 568 times.